

## 51 44 910 Releasing and securing the headlining on the left



**Fold the headlining.**

**If the headlining is folded, it may have to be replaced.**

- Carry out tasks with a second person to assist.
- Support the headlining at the front and back.

### PRELIMINARY WORK

#### 1 – Remove rear seat bench

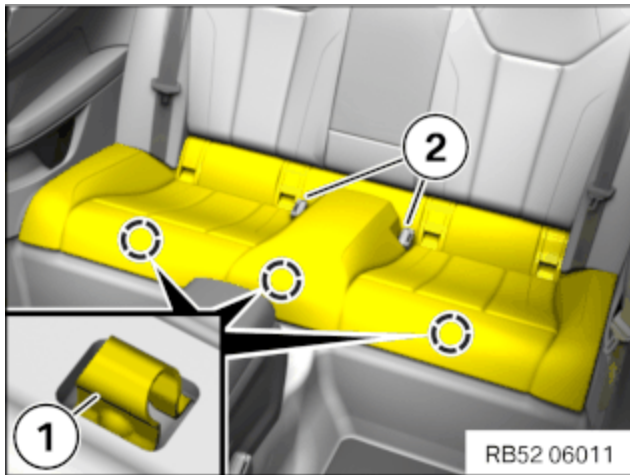

- Unclip the rear seat bench upwards from clamps (1) and guide out seat belt buckles (2).
- Remove the rear seat bench.

#### 2 – Remove armrest side section

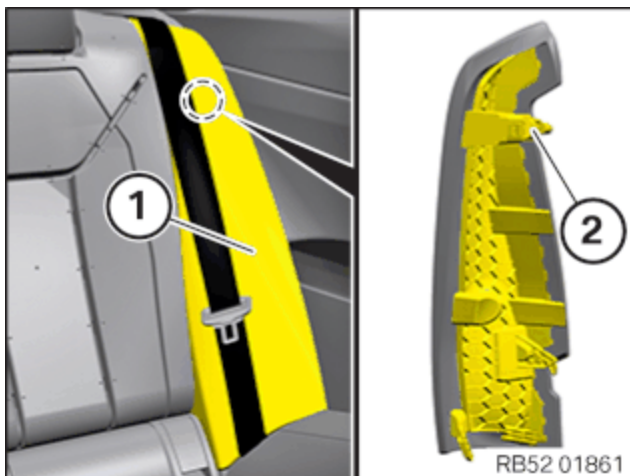

#### ► Remove armrest side section

- Reach behind the backrest side section (1) from the top and unclip the backrest side section (1) from the mounting element (2) to the front.
- Remove backrest side section (1) in the upward direction from the guide.



Ads by Google

Stop seeing this ad

Why this ad?

**Deactivation of the 12 V vehicle electrical system.****Risk of short circuits! Risk of fire!**

- Make sure that **no battery charger** is connected to the jump start terminal point in the engine compartment.
- For vehicles with additional electrical systems (48 V electrical system, high-voltage vehicle electrical system), it is mandatory to deactivate them **before** disconnecting the vehicle battery.

**Deactivation of the 48 V electrical system.****Risk of short circuits! Risk of fire!**

- Make sure that **no charger** is connected to the jump start support point in the engine compartment.

**Damage to 48-V battery**

**If a 48-V battery that is disconnected from the electrical system is activated, the battery electronics will be damaged.**

- Only carry out activation of the 48V electrical system with a completely connected 48-V battery.



Follow notes for 48-V battery. See further information 6120 ... Notes on 48-V battery.



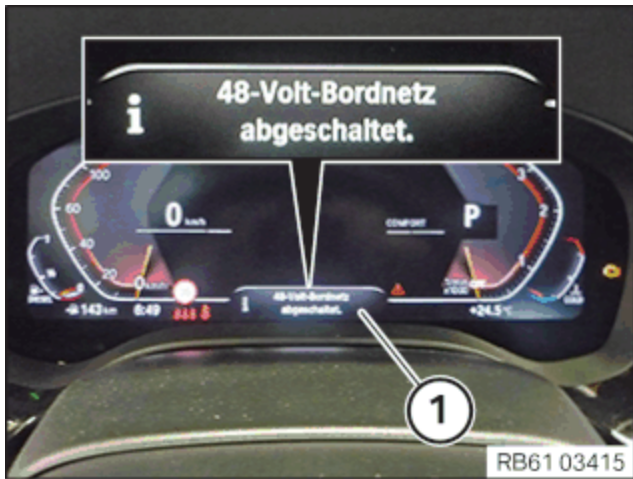

## Check



Zero voltage (48V electrical system is switched off) is displayed only in PAD mode.

- Press the START-STOP button quickly 3 times without stepping on the brake pedal to establish the PAD mode.
- Check isolation from the supply in the instrument cluster in PAD mode.



system switched off:" (1). Work is not permitted to be started.

### Measure

- Carry out the service function "48 V electrical system deactivation".
  - Vehicle management > Service functions > Voltage supply > Deactivate 48 V electrical system

Only when the Check Control message "48 V electrical system switched off." (1) is displayed in the instrument cluster is it permitted to disconnect the 12 V battery.

**If the absence of voltage is not indicated clearly, contact Technical Support.**

### Result

- » The Check Control message signals that the 48V electrical system has been switched off.

### Measure

- Exit PAD mode by pressing the START-STOP button once without depressing the brake pedal.

The work "Disconnecting the negative battery cable of the 48-V battery" can be started.

- Unlock and disconnect plug connection (1) of the CAN bus.
- Release the clip (2).

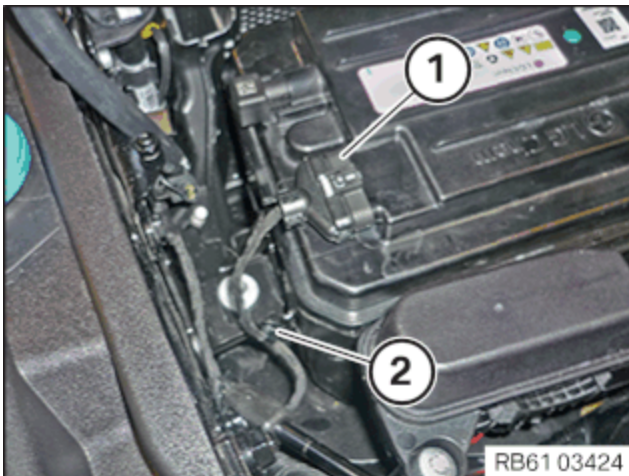

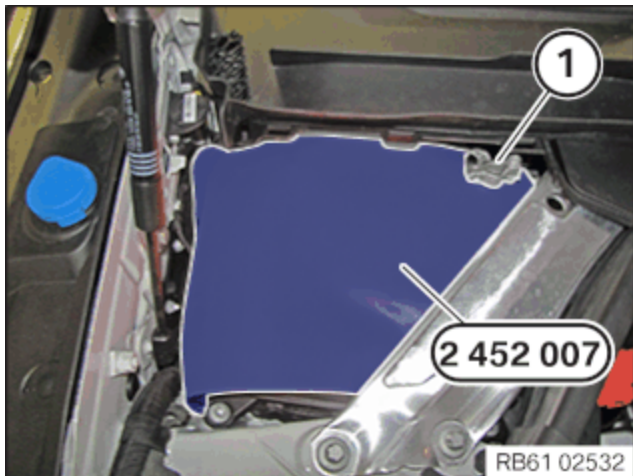

**Unprotected battery terminals.**

**Risk of short circuits! Risk of fire!**

- Cover the vehicle battery.

- Cover the vehicle battery with the special tool as shown.
- Position the battery earth lead (1) as shown.

### ► Disconnecting all battery earth leads

- See additional information.



### ► Removing backrest side section with side airbag



battery.

- Airbag unit may only be set down with the cushion (airbag itself) facing upwards.
- For additional information see: 72 00 ... Safety regulations on handling airbag system components/gas generators



### Pyrotechnic components.

#### **Danger! Life-threatening injuries!**

- All work on pyrotechnic parts may be carried out by technically experienced and appropriately trained personnel only.
- Replace any damaged part or ones that have been dropped.
- For additional information see: 72 00 Safety regulations on handling components with gas generators.



To provide a better overview: Schematic diagram with partially hidden components.

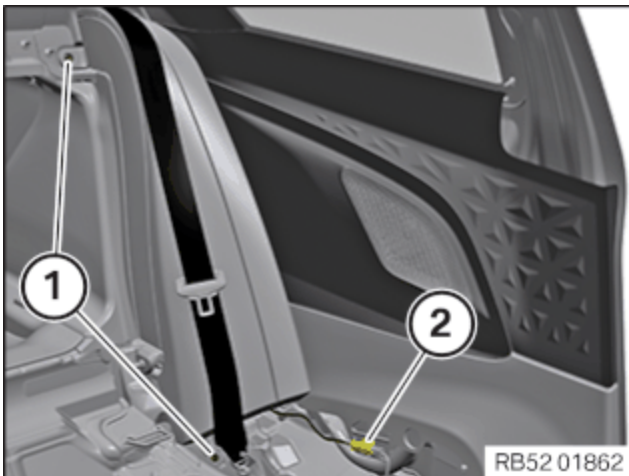

- Loosen screws (1).
- Unlock plug connection (2) and disconnect.





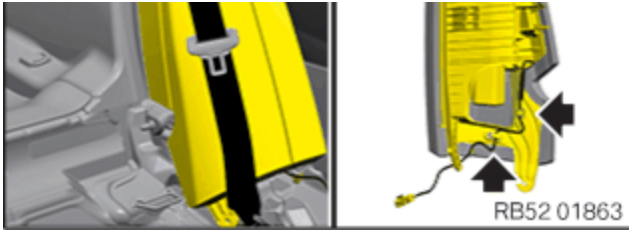

### 3 – Removing the inner door sill cover strip



#### Bending of plastic parts.

#### Application of too much force can lead to bending of plastic parts.

- Place special tool directly beside the mounting clip.
- Continue unclipping the part without using the tool if possible.



Schematic diagram is for example purposes. Some parts may differ in certain details.

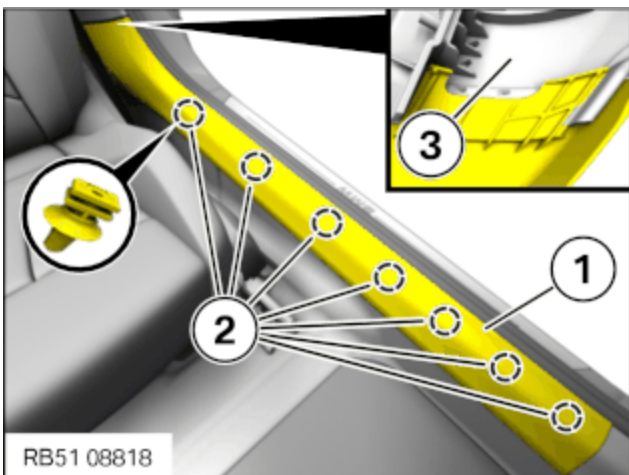

- Release door sill cover strip (1) with clips (2) starting from the front using a suitable special tool from the set of special tools **0 493 752 (00 9 329)**.
- Guide out and remove door sill cover strip (1) under the rear side trim panel (3) .



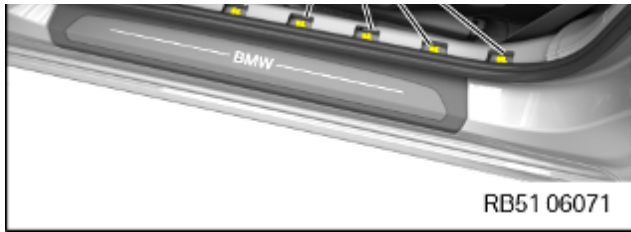

#### 4 – Remove the belt feed trim

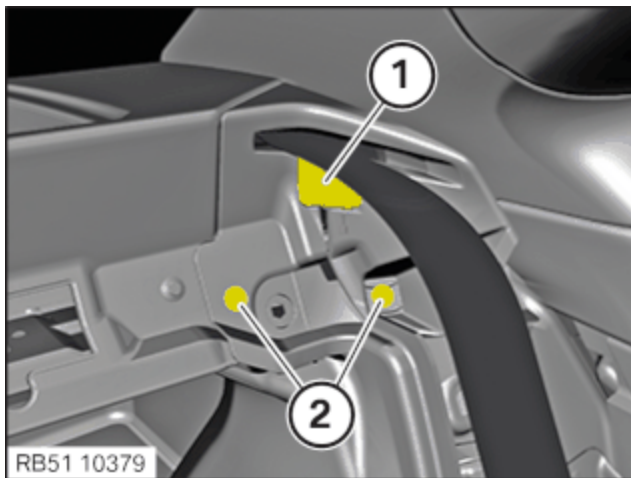

- Unclip the trim (1) with a suitable tool.
- Release the expanding rivet (2).

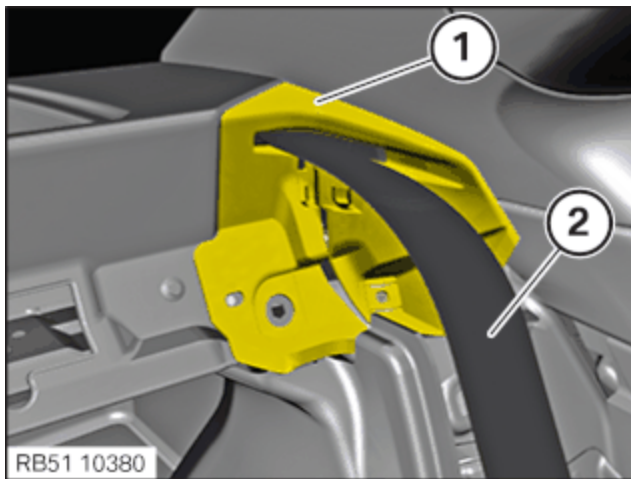

- Unclip the seat belt feed trim (1) and feed it out from the seat belt (2).

#### 5 – Remove rear side trim panel

##### Prerequisite







- Check and disconnect all the plug connections of the wiring harness on the rear side trim panel (1).

## 6 – Removing the trim of the additional brake light

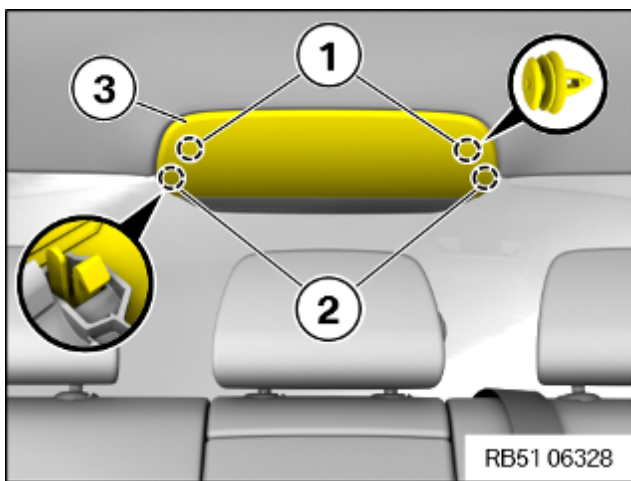

- Loosen the clips (1).
- Release the latch mechanisms (2) and remove the trim of the additional brake light (3).

## 7 – Remove the B-pillar trim panel



Schematic diagram is for example purposes. Some parts may differ in certain details.

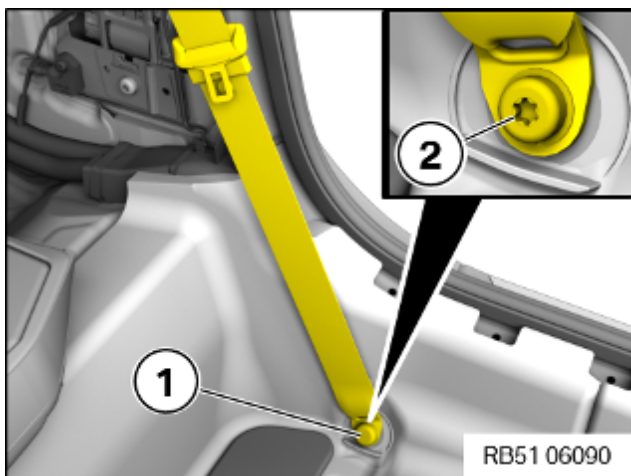

- Remove cover cap (1) and release screw (2).



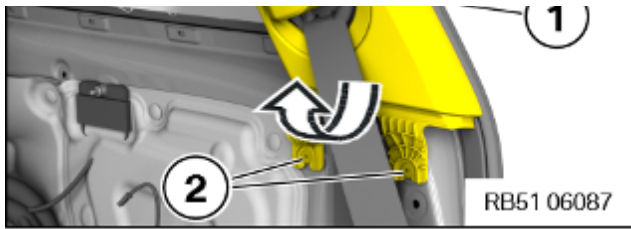

- Feed upper seat belt (2) out of B-pillar trim panel (1).

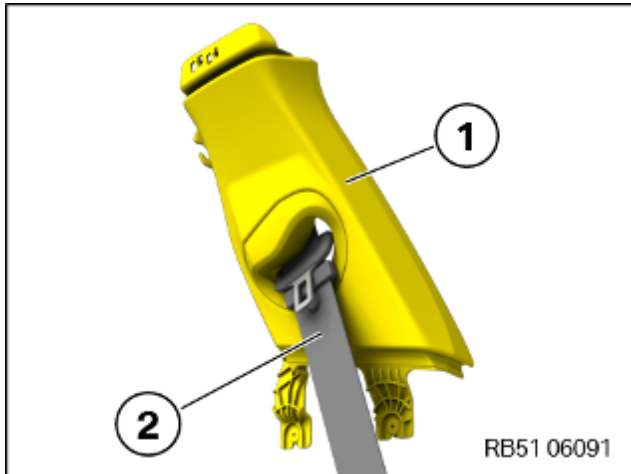

## 8 – Remove C-pillar trim panel

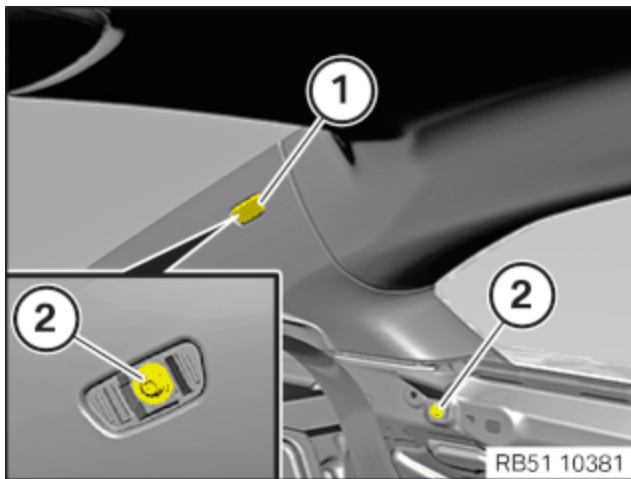

- Unclip the cover (1).
- Loosen screws (2).



## 9 – Remove interior roof light

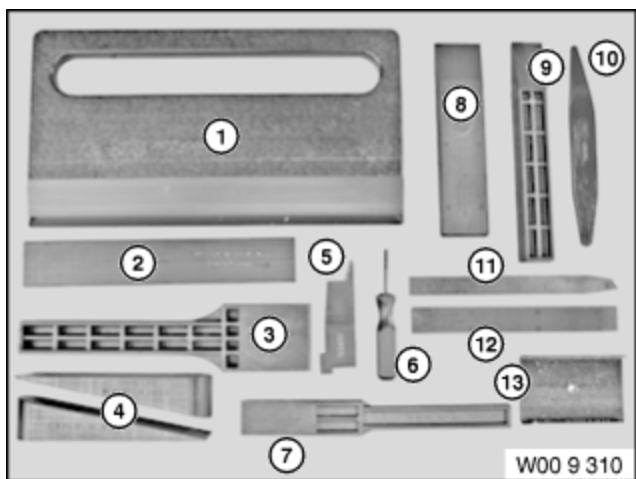

- Have the set of special tools **0 493 752 (00 9 329)** ready.

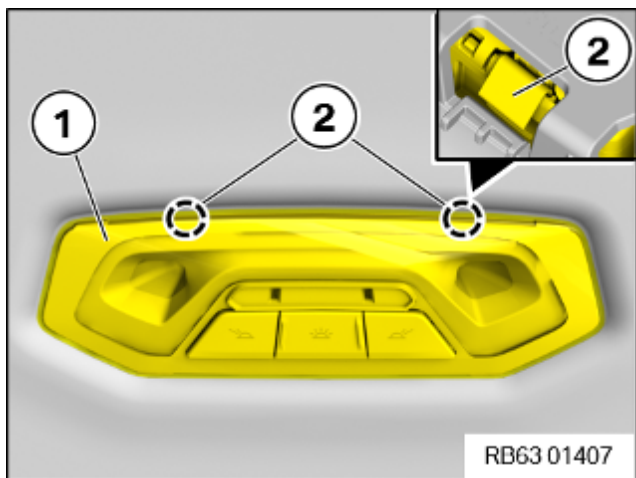

- Lever interior roof light (1) out of clamps (2) using a suitable tool.
- Unlock plug connection and disconnect.



**Danger. Life threatening injuries.**

- All work on pyrotechnic parts may be carried out by technically experienced and appropriately trained personnel only.
- Replace any damaged part or ones that have been dropped.
- For additional information see: 72 00 Safety regulations on handling components with gas generators.

**Damage to the head airbag.**

**Improper use of a tool when removing the trim panel may damage the head airbag.**

- Do not use sharp-edged tools when removing the trim panel.

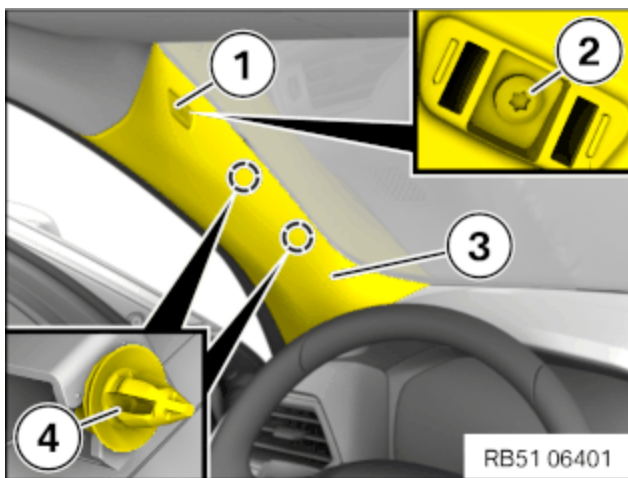

- Unclip cover (1) with a suitable special tool from the special tool kit **0 493 752 (00 9 329)**.
- Loosen screw (2).
- Unclip A-pillar trim panel (3) with clips (4) and feed it out to the top.



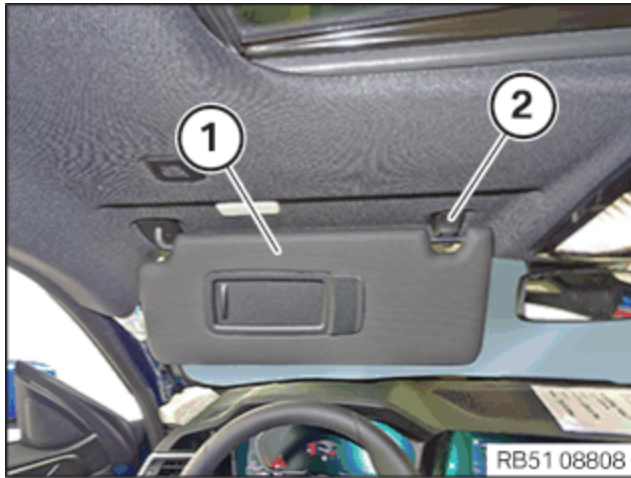

- Detach sun visors (1) from end support (2) and swivel to the side.

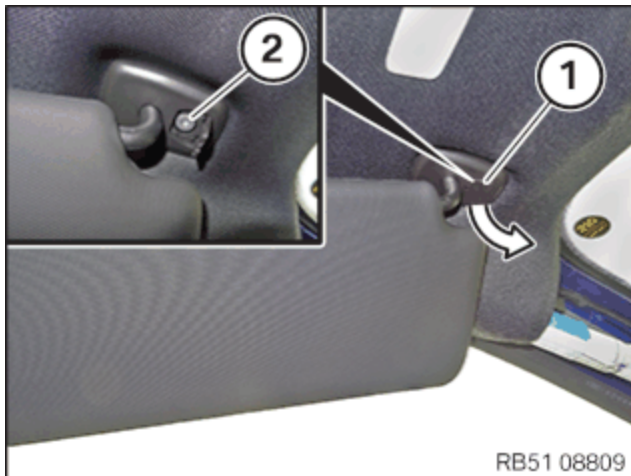

- Fold the cover (1) up in direction of arrow.
- Loosen screw (2).
- Remove sun visor and unlock and disconnect the associated plug connection.

## 12 – Remove the counter support for the sun visor

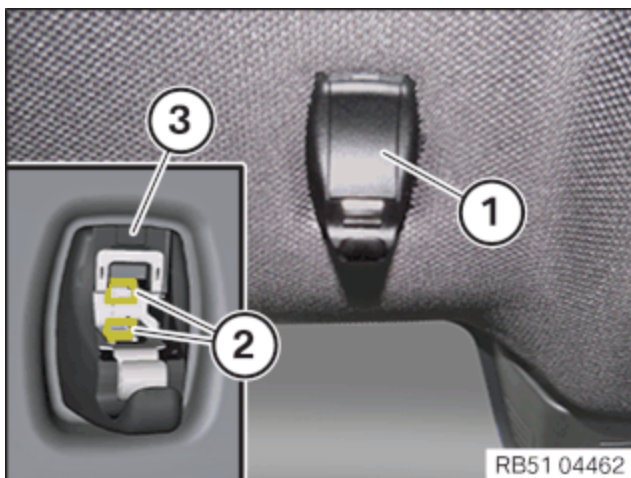

- Pull out the cover (1).
- Push the clamps (2) together and pull the counter support (3) out of the headlining.





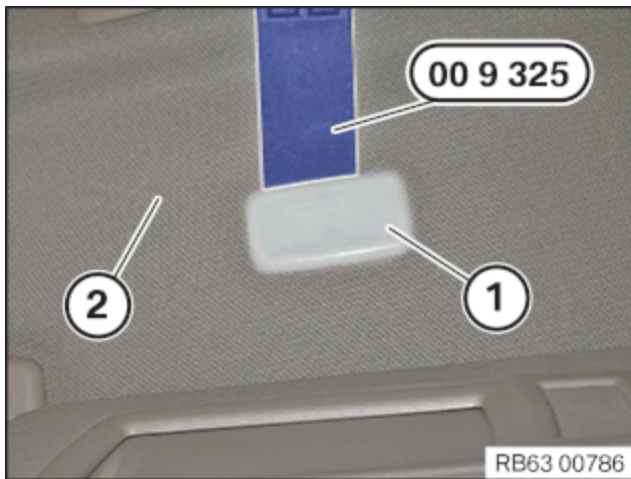

- Lever out the front vanity mirror light (1) with the special tool **0 496 569 (00 9 325)** from the headlining (2).

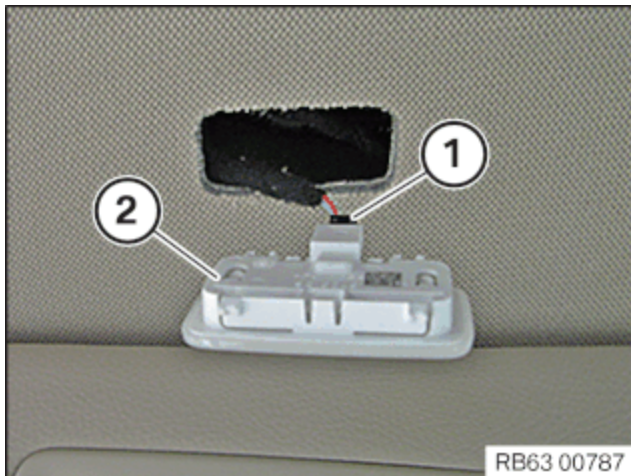

- Unlock plug connection (1) and disconnect.
- Remove the front vanity mirror light (2).

## 14 – Remove left and right hands-free microphone



Description is for left component only. Procedure on the right side is identical.

### ► Removing hands-free microphone





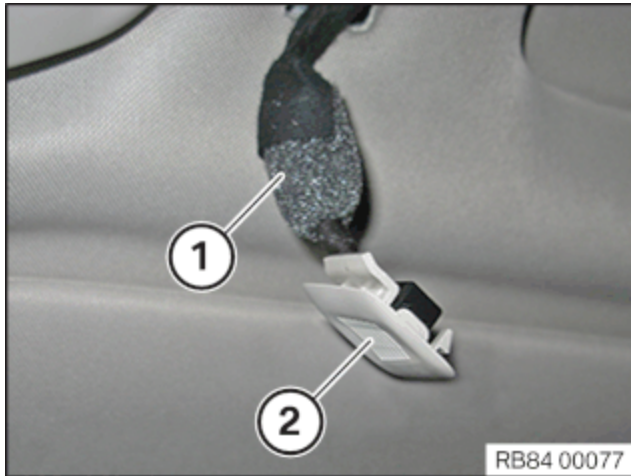

- Open insulation (1).
- Disconnect plug connection.
- Remove hands-free microphone (2).

## 15 – Removing the roof function centre (FZD)



- Unclip the cover (1).



- Unclip the roof function centre (FZD) (1) from the clamps (2).
- Thread the roof function centre (FZD) (1) out of the guides (3).

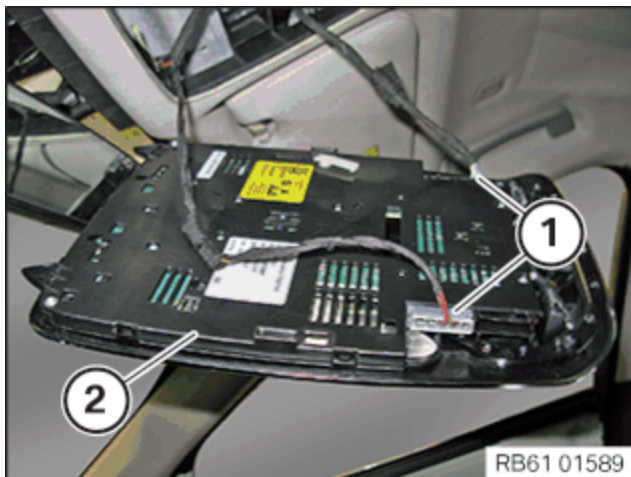

- Unlock and disconnect plug connections (1).
- Unclip the cable clip from roof function centre (FZD) (2) and remove the roof function centre (FZD) (2).

## 16 – Removing the covers for the interior mirror

- **Version A:**



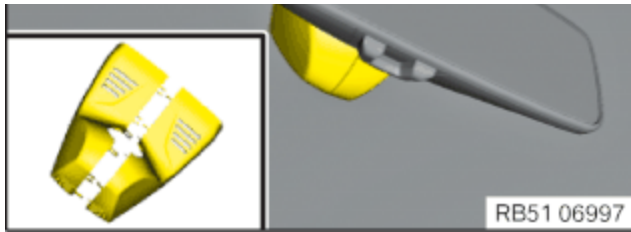

- **Version B:**

- Release the cover (1) from the latch mechanisms (2) with a suitable plastic wedge and remove sideways.

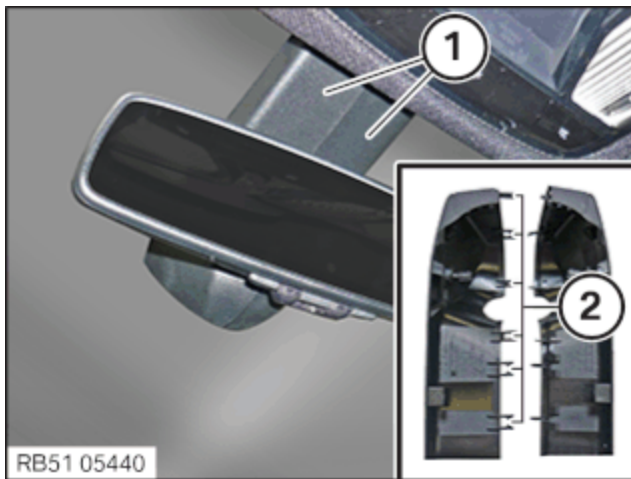

- **Version C:**

- Detach cover (1) from the clamps (2) in the marked area using a suitable plastic wedge and pull down a certain distance.
- Release cover (1) at the retaining lugs (3) and remove from the guides to the rear.

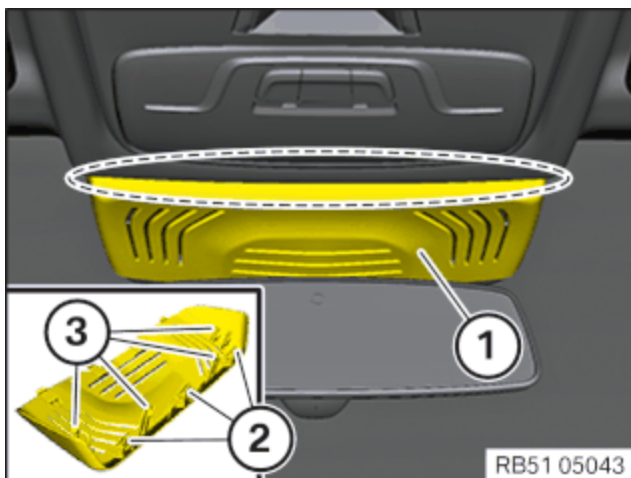

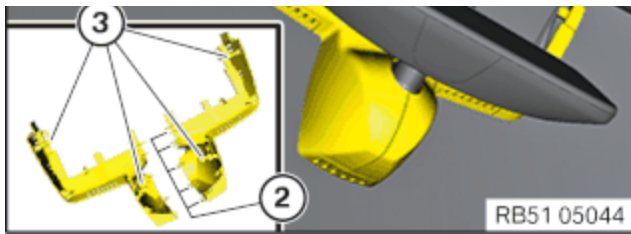

- **Version D:**

- Release covers (1) and (2) using a suitable plastic wedge at the separation point (3) and remove from the side.

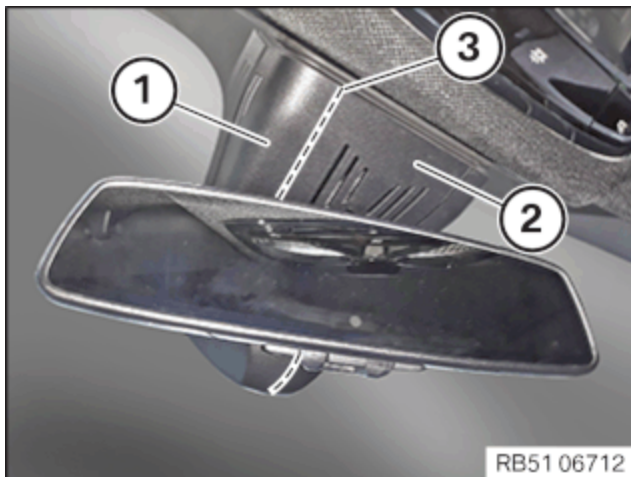

## MAIN WORK

### 17 – Lowering the headlining on the left or right

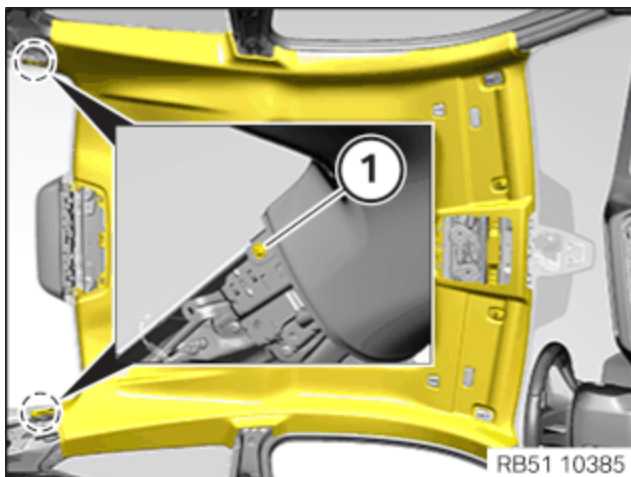

- Loosen screw (1).







Schematic diagram is for example purposes. Some parts may differ in certain details.

- Guide out the headlining at the respective edge protection.
- Lower the headlining and place it onto the head restraints as shown.

## 18 – Install the headlining (lowered)

### Prerequisite

The front seats have been fully adjusted towards the bottom.

The front seat backrests have been fully adjusted towards the rear.

The rear seat backrest is folded down toward the front.

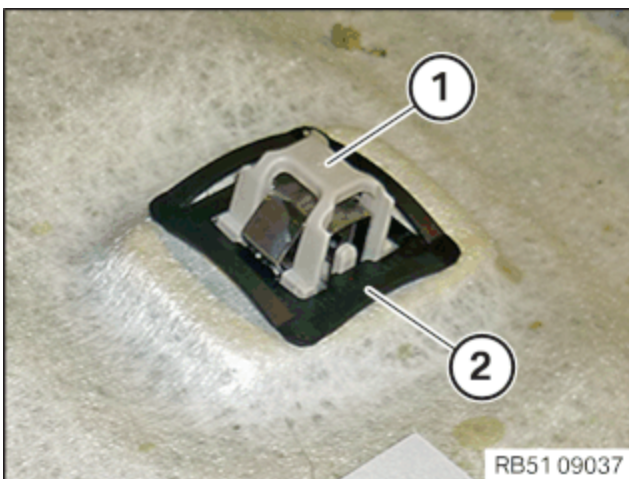

- Install the end support (1) of the sun visors in the headlining and mount with clamps (2).



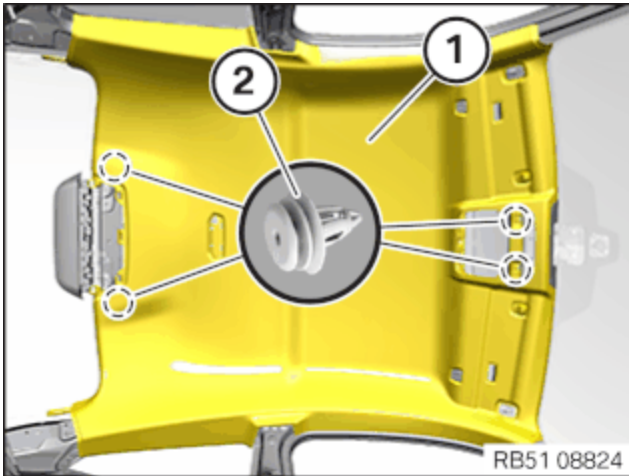

- Insert the headlining (1) with the help of an auxiliary person onto the respective edge protection.
- Clip in headlining (1) on the clips (2).

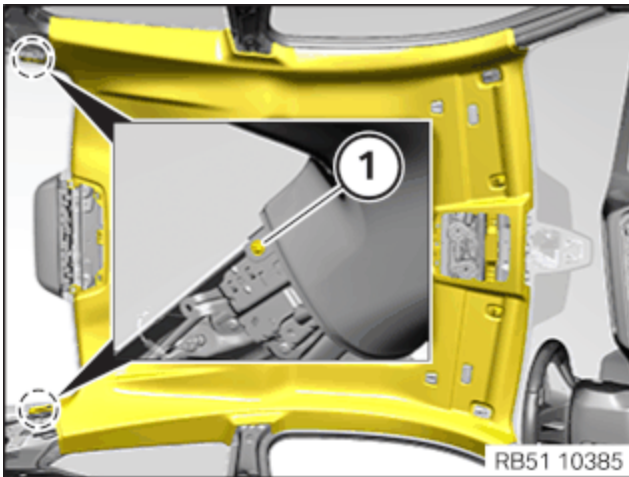

- Tighten the screws (1).

#### Headlining to C-pillar

Oval-head  
screw

Tightening  
torque

1.6 Nm

## POSTPROCESSES

### 19 – Installing the covers for the interior mirror

- **Version A:**





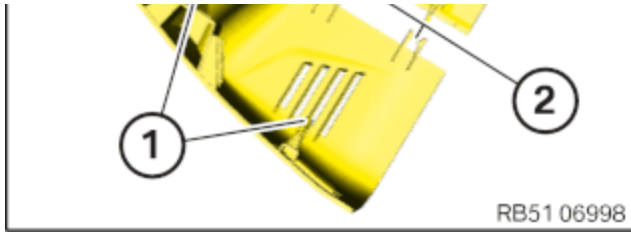

- Feed cover (1) in and lock.

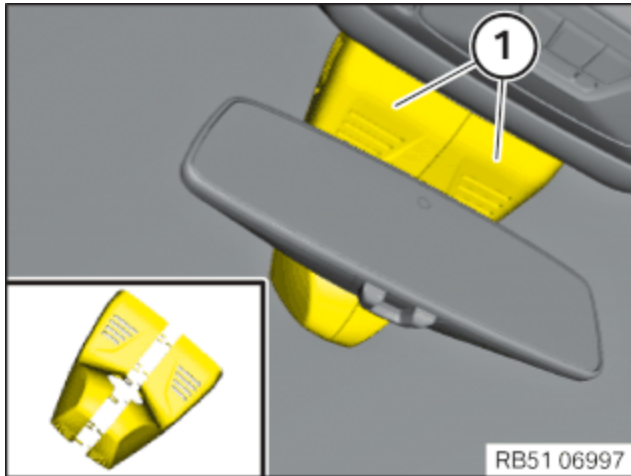

- **Version B:**

- Check the latch mechanisms (1) on the two covers (2) for damage, renew the covers (2) if necessary.

The covers (2) must not be damaged or missing.

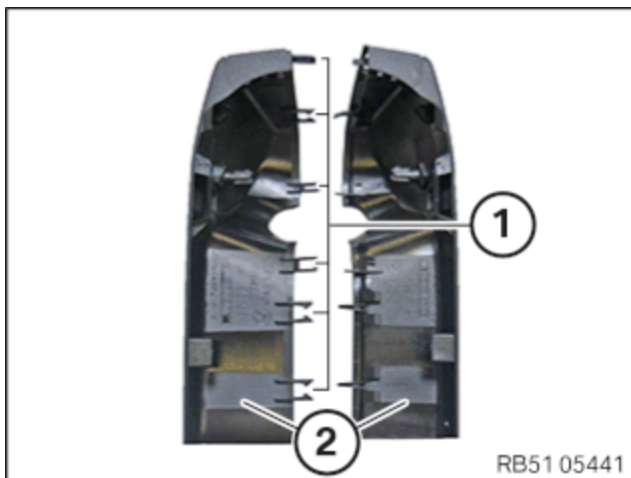



- **Version C:**

**Check**

- Check the latch mechanisms (1) and (2) of the covers for damage.

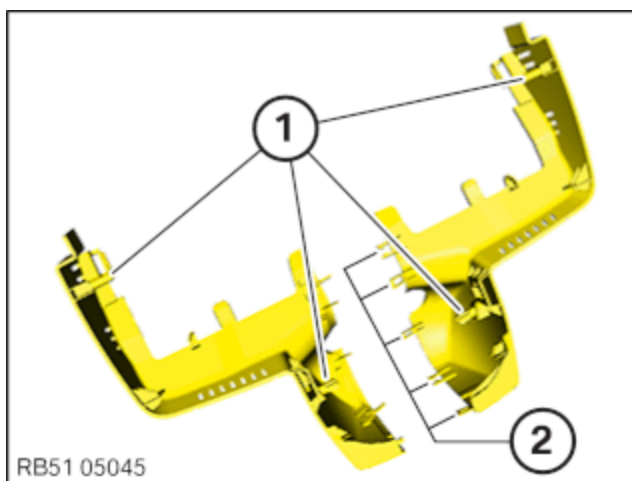

**Result**

- » The latch mechanism is damaged.

**Measure**

- Renew the cover.
- Guide in cover (1) on left and right and engage using latch mechanisms (2) and (3).

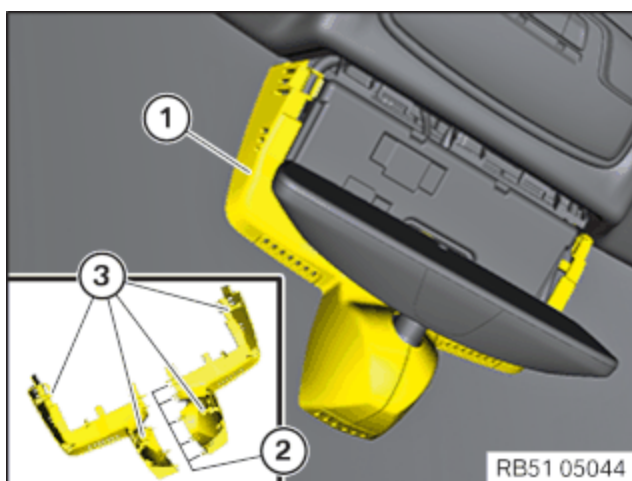

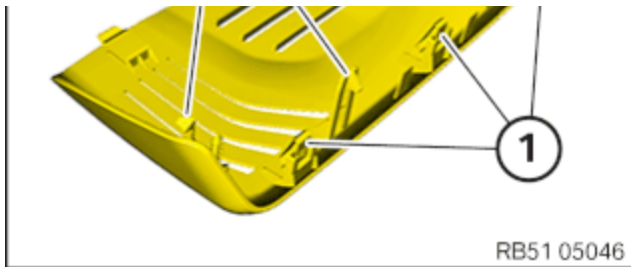

### Result

» The latch mechanism is damaged.

### Measure

- Renew the cover.
- Guide cover (1) into front guides and engage using retaining lugs (3) and clamps (2).

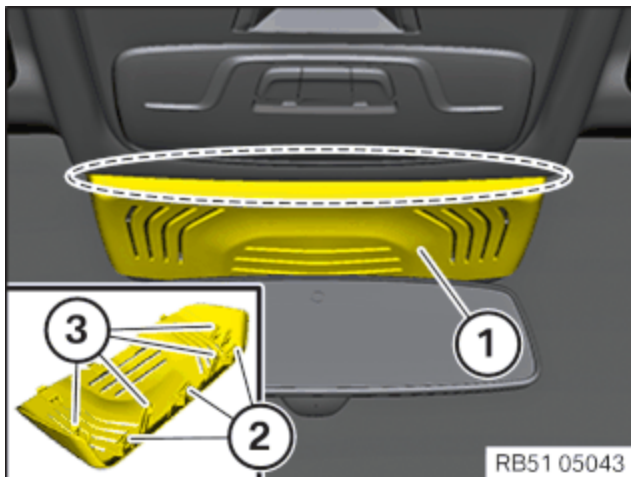

### • Version D:

- Check the latch mechanisms (arrows) on covers (1) and (2) for damage and, if necessary, renew covers (1) and (2).

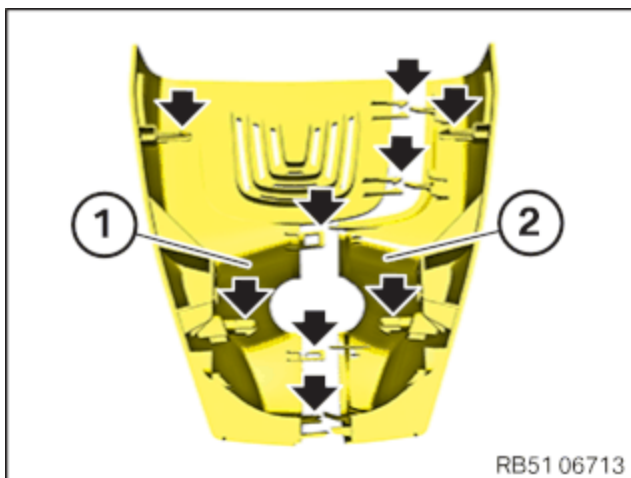



## 20 – Installing roof function centre (FZD)

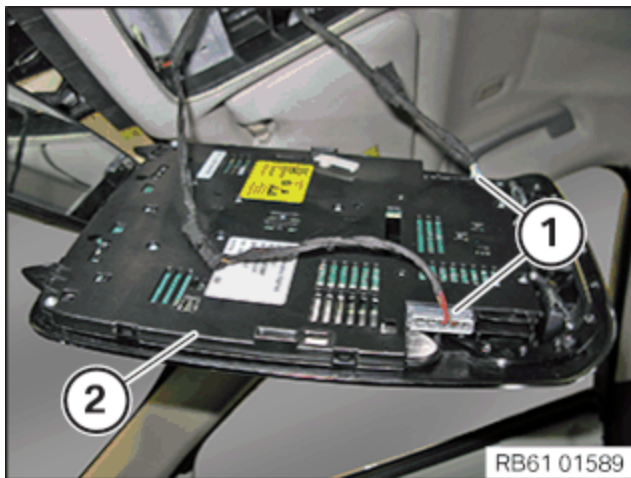

- Connect connectors (1) and lock.
- Clip in the cable for the roof function centre (FZD) (2) in the cable clip.

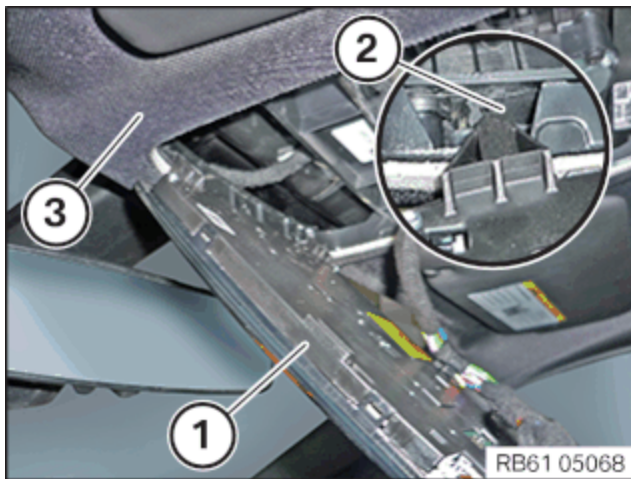

- Insert the roof function centre (FZD) (1) as shown at a steep angle in the two guides (2) on the headlining (3).
- Make sure the headlining is not deformed during this operation.



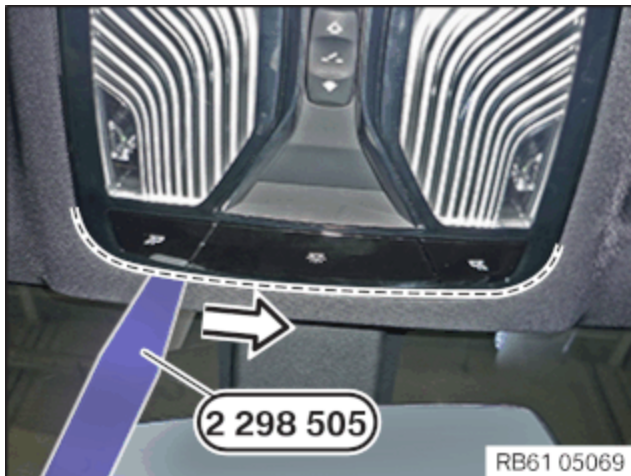

- Slide the special tool **2 298 505** in the direction of arrow between the FZD frame and the headlining along the dotted line to adjust the headlining correctly.



- Tighten the screws (1).

#### **Roof function centre (FZD)**

Tightening torque	1.2 Nm
-------------------	--------







## 21 – Installing the hands-free microphone on the left and right



Description is for left component only. Procedure on the right side is identical.

### ► Installing the hands-free microphone

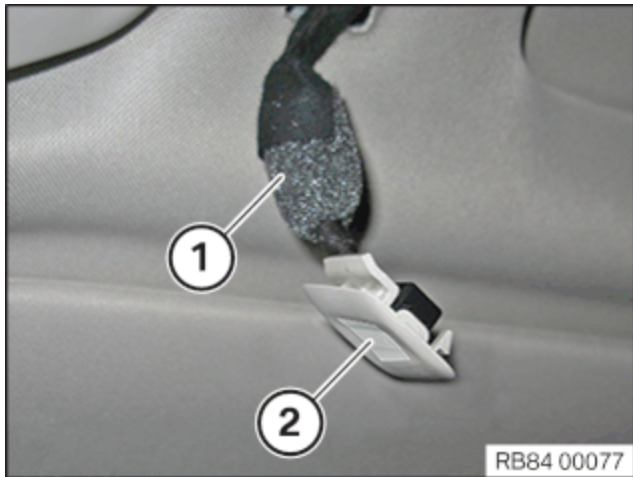

- Connect the connector to the hands-free microphone (2).
- Close the insulation (1).

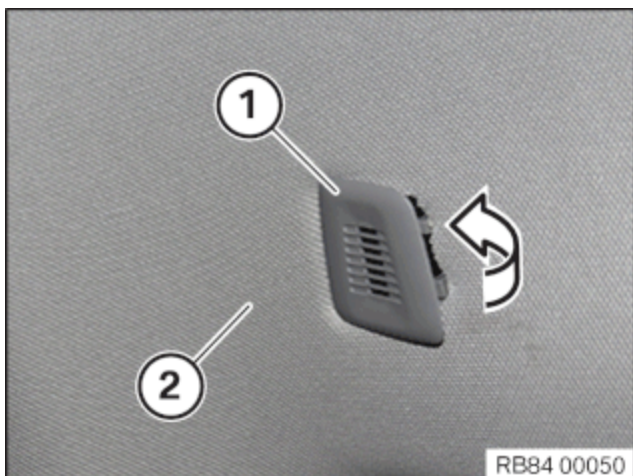

- Insert the hands-free microphone (1) in the direction of arrow in the headlining (2).





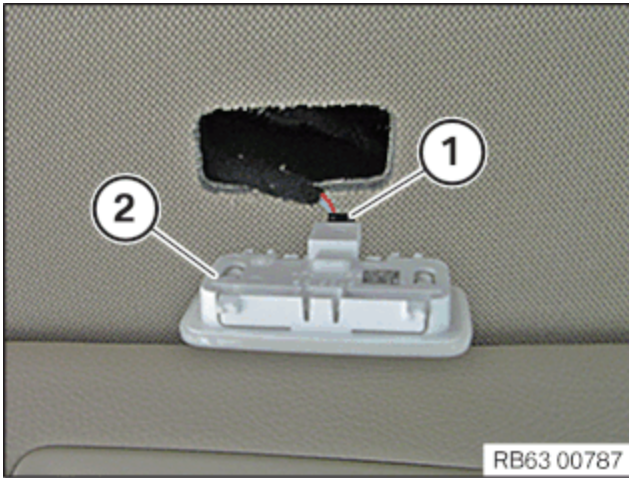

- Connect the connector (1) to the front vanity mirror light (2).

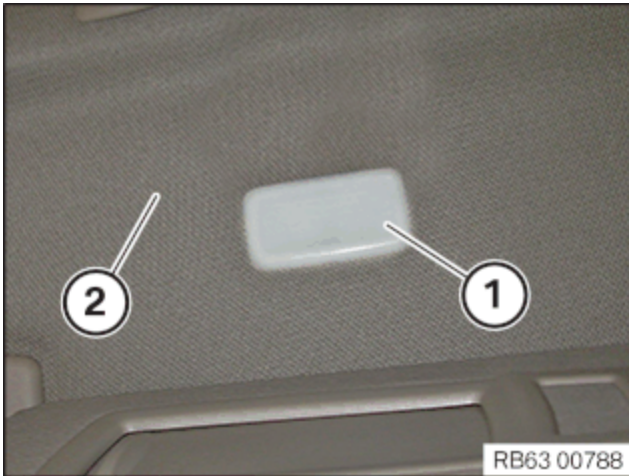

- Clip in the front vanity mirror light (1) in the headlining (2).

### 23 – Install the counter support for the sun visor

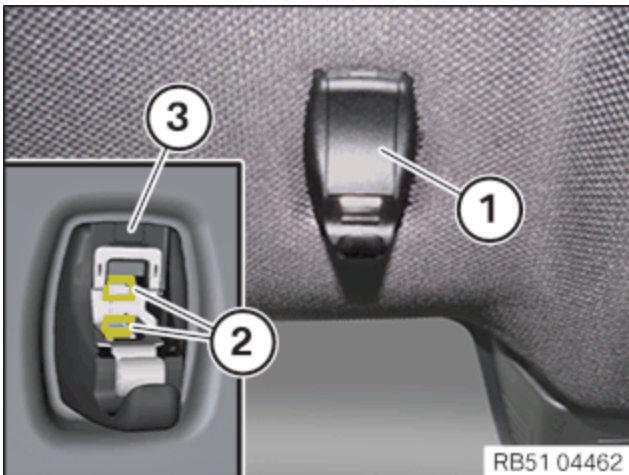

- Insert the counter support (3) into the headlining.
- Make sure the clamps (2) are engaged correctly.
- Use cover (1).



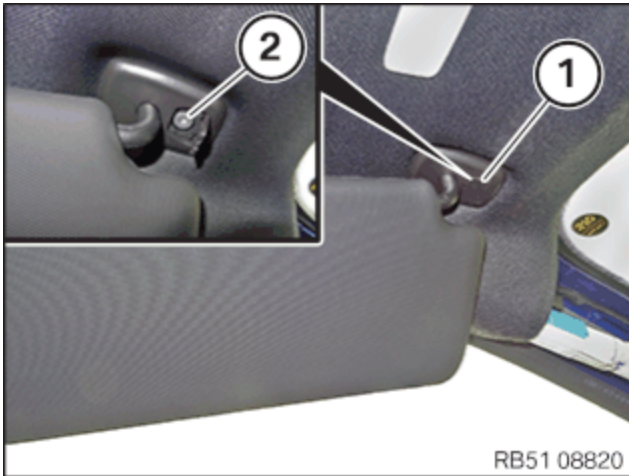

- Connect and lock corresponding connectors.
- Install the sun visors.
- Tighten down screw (2).
- Close the cover (1).

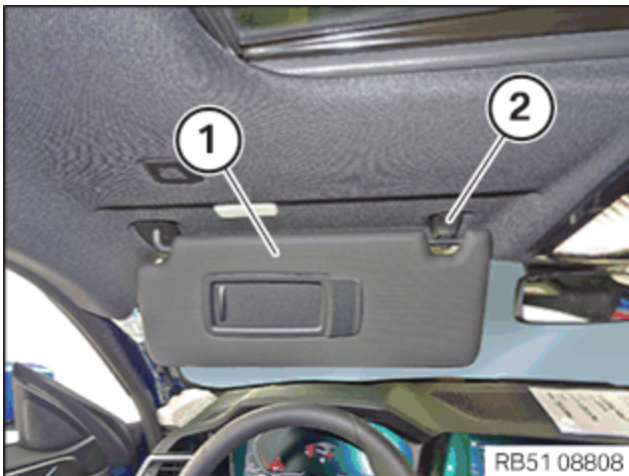

- Hook the sun visors (1) to the end support (2).



**Danger. Life threatening injuries.**

- All work on pyrotechnic parts may be carried out by technically experienced and appropriately trained personnel only.
- Replace any damaged part or ones that have been dropped.
- For additional information see: 72 00 Safety regulations on handling components with gas generators.

**Damage to the head airbag.**

**Improper use of a tool when removing the trim panel may damage the head airbag.**

- Do not use sharp-edged tools when removing the trim panel.

**Check**

- Check retaining lugs (1) of cover (2) for damage.

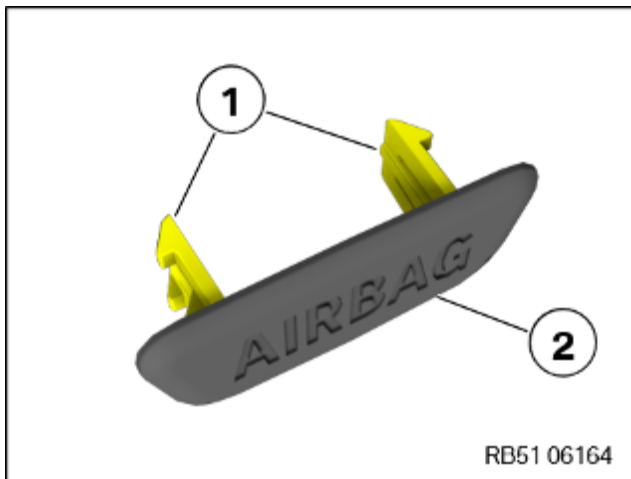

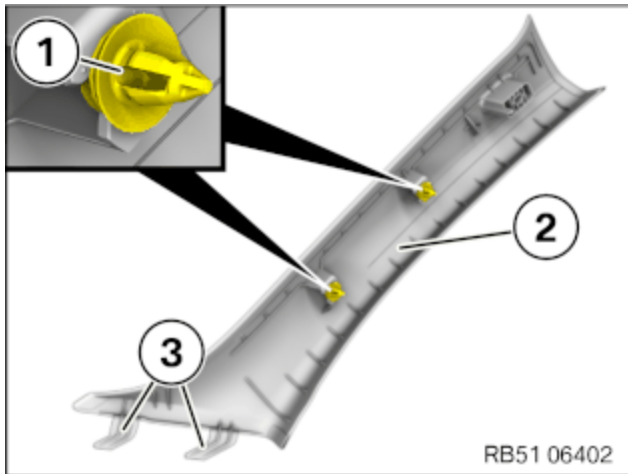

- Check the clips (1) for damage and renew if necessary.
- Check the guides (3) for damage.

### Result

» Guide is damaged.

### Measure

- Renew the A-pillar trim panel.

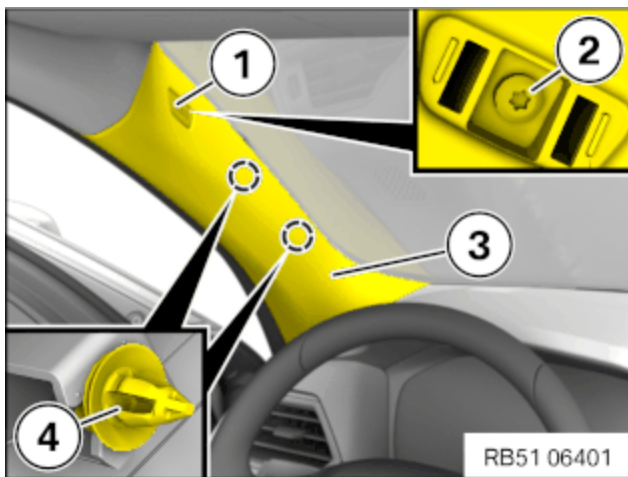

- Guide in A-pillar trim panel (3) downwards and clip it in with clips (4).
- Tighten down screw (2).

### A-pillar trim panel to body

Sheet  
metal  
screw  
4,8x38

Tightening  
torque

2,6 Nm

- Clip in the cover (1).

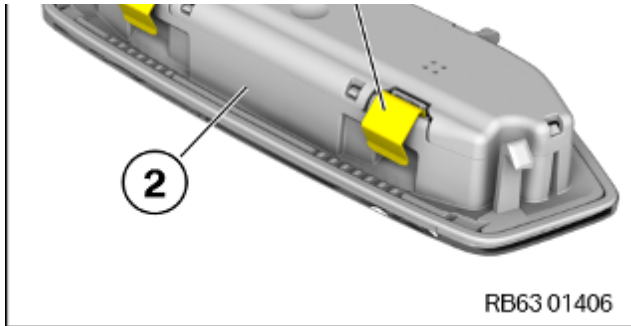

### Result

» Clamps (1) are damaged.

### Measure

- Renew the interior roof light (2).
- Connect connectors and lock.
- Clip in the interior roof light (1) with clamps (2).

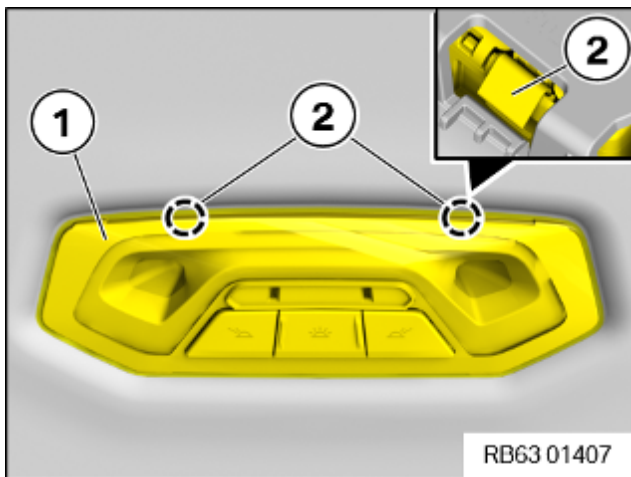

## 27 – Installing C-pillar trim panel

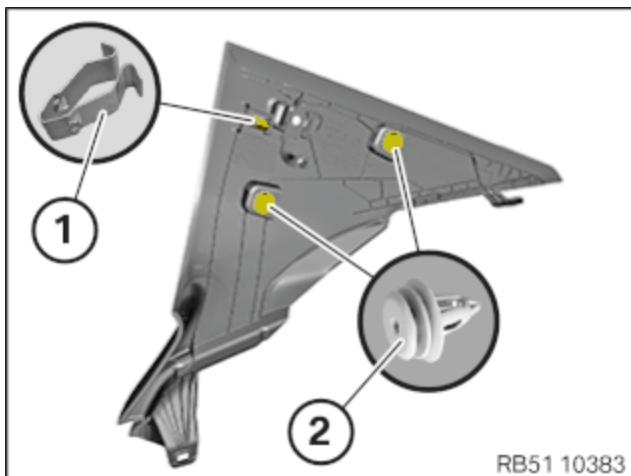

- Check the clamp (1) and the clips (2) for damage and correct fit, renew if necessary.



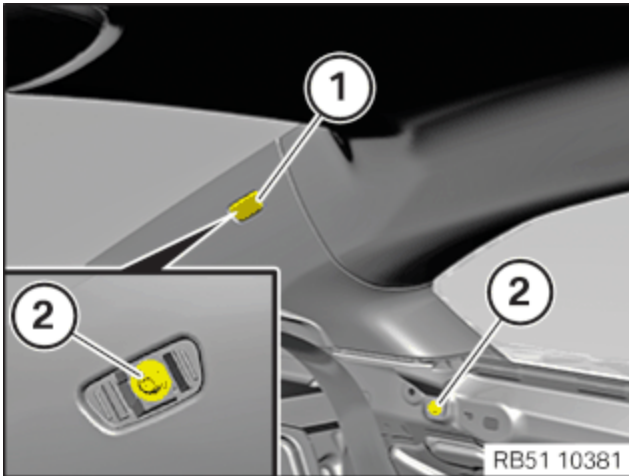

- Tighten the screws (2).

#### C-pillar trim panel to body

Sheet  
metal  
screw

Tightening  
torque

2 Nm

- Clip in the cover (1).

## 28 – Install the B-pillar trim panel



Schematic diagram is for example purposes. Some parts may differ in certain details.

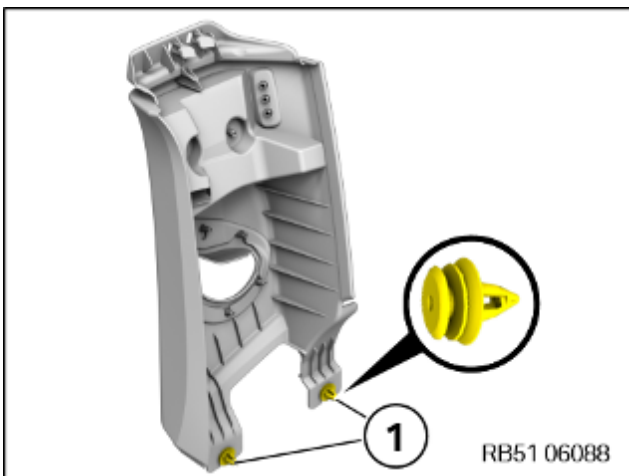

- Check clips (1) for damage and renew if necessary.





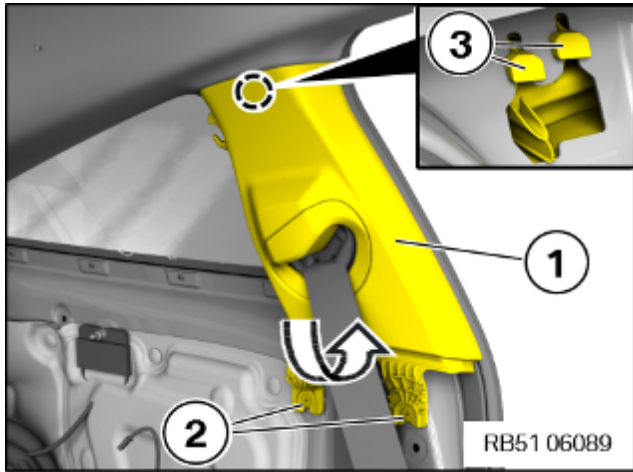
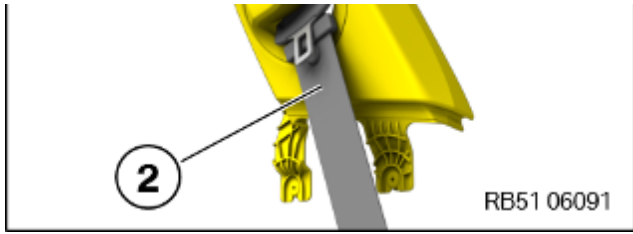

- Insert B-pillar trim panel (1) in direction of arrow into the guides (3) and under the lip of edge protection.
- Clip in the B-pillar trim panel (1) with the clips (2).

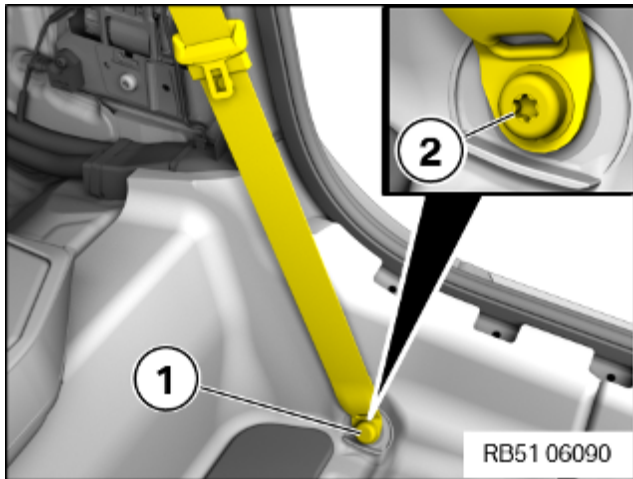

- Tighten down screw (2).

**End fitting to body**

Screw	Tightening torque	42 Nm
-------	-------------------	-------

- Install the protective cap (1).



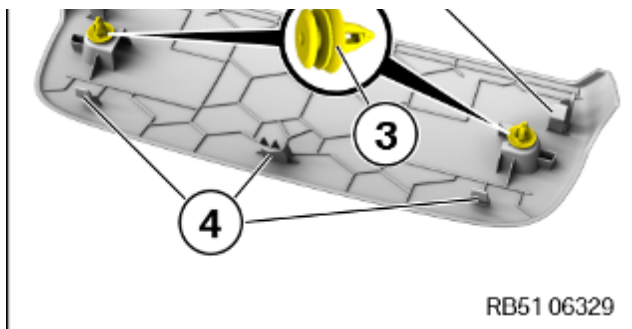

damage.

### Result

» The latch mechanism or the guide is damaged.

### Measure

- Renew the trim for the additional brake light.
- Position trim for additional brake light (1) from the bottom and clip it in with latch mechanisms (2).
- Clip in clips (1).

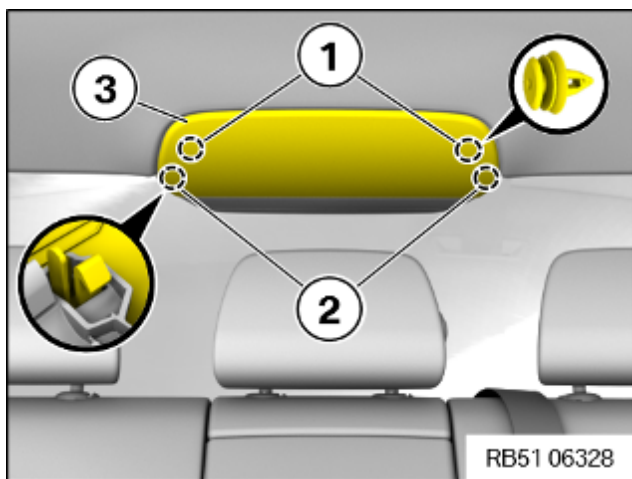

## 30 – Install rear side trim panel

### Prerequisite



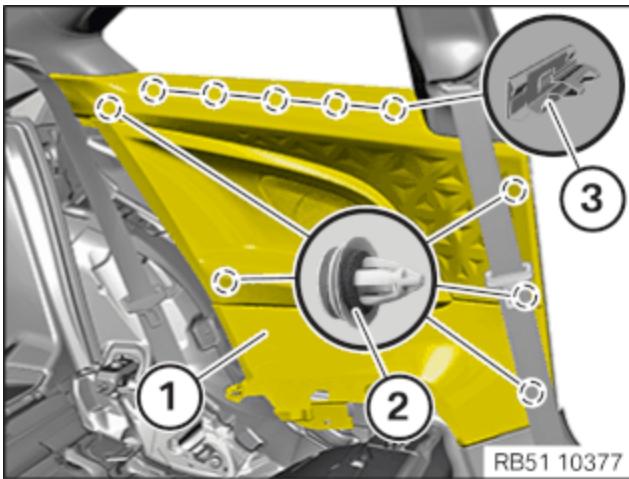
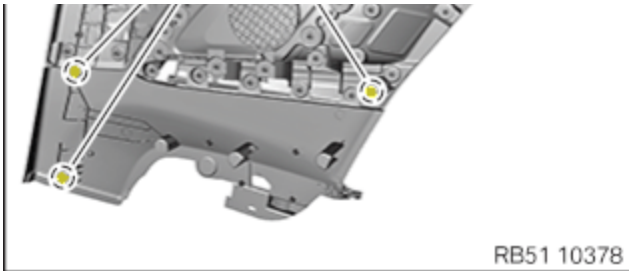

- Connect all the plug connections of the wiring harness on the rear side trim panel (1) and lock them.
- Position the rear side trim panel (1) and clip it into the clamps (3).
- Clip the rear side trim panel (1) into the clips (2).

### 31 – Installing the belt feed trim

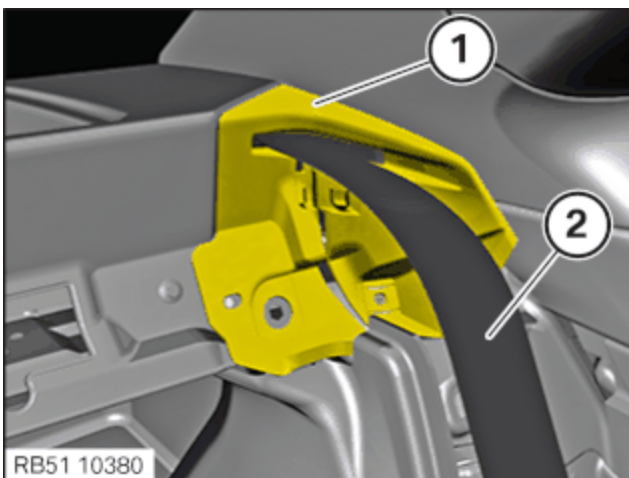

- Feed in the seat belt feed trim (1) at the seat belt (2).
- Position the seat belt feed trim (1) and clip it in.



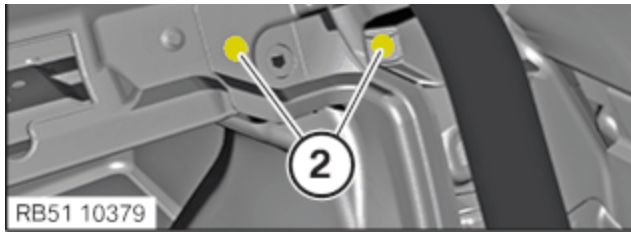

### 32 – Installing the inner door sill cover strip

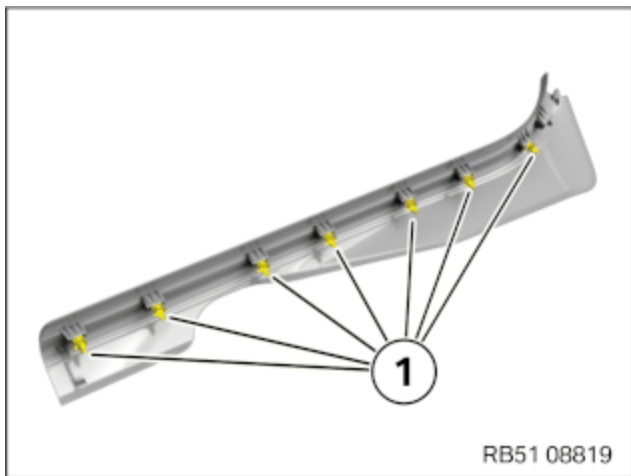

Schematic diagram is for example purposes. Some parts may differ in certain details.

- Check the clips (1) for damage and renew if necessary.
- Insert the door sill cover strip (1) below the rear side trim panel (3).
- Clip the door sill cover strip (1) in with the clips (2).

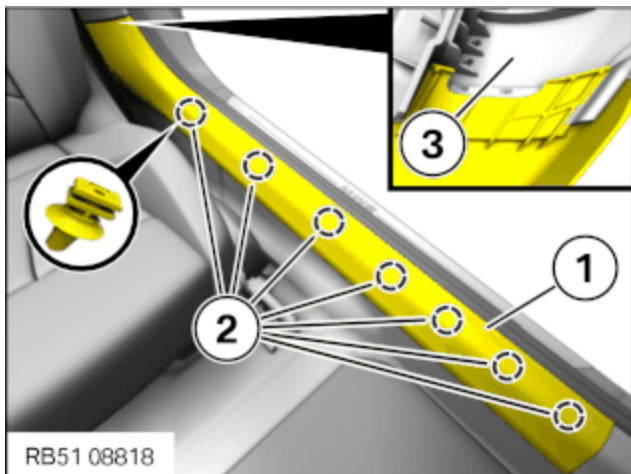

### 33 – Installing backrest side section

#### ► Installing backrest side section





- Fit mounting element (1) on the backrest side section.

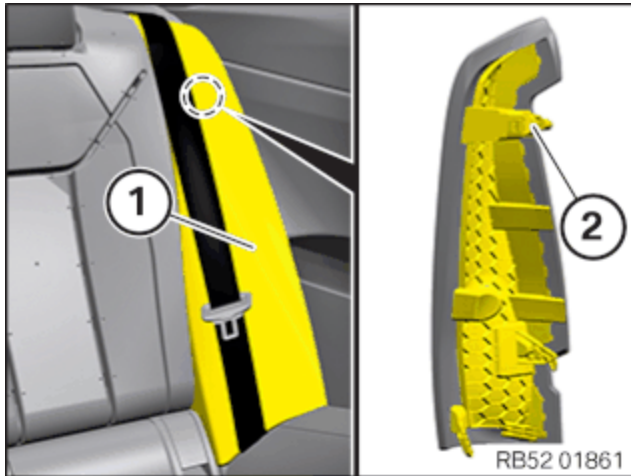

- Insert lower backrest side section (1) into the guide and position it correctly.
- Clip in backrest side section (1) to mounting element (2).

► **Installing the backrest side section with side airbag**





battery.

- Airbag unit may only be set down with the cushion (airbag itself) facing upwards.
- For additional information see: 72 00 ... Safety regulations on handling airbag system components/gas generators



### Pyrotechnic components.

#### Danger! Life-threatening injuries!

- All work on pyrotechnic parts may be carried out by technically experienced and appropriately trained personnel only.
- Replace any damaged part or ones that have been dropped.
- For additional information see: 72 00 Safety regulations on handling components with gas generators.



To provide a better overview: Schematic diagram with partially hidden components.

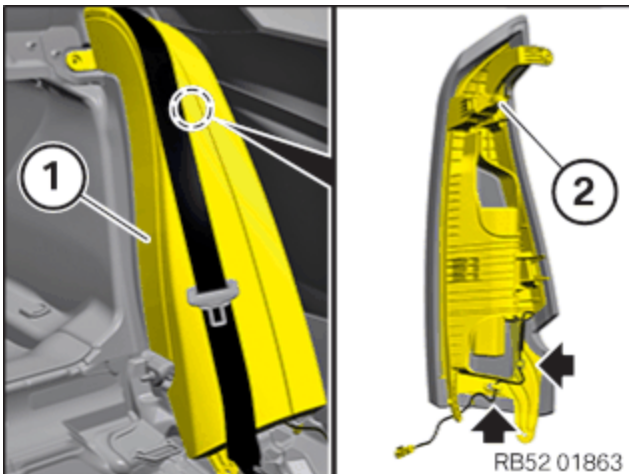

- Check the cable (arrows) for correct fit.
- Feed the backrest side section (1) into the bottom guide and position it correctly.
- Clip in backrest side section (1) to mounting element (2).



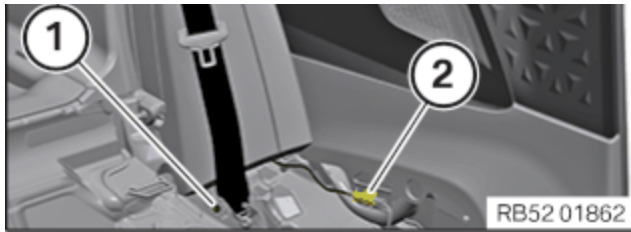

- Connect connectors (2) and lock.
- The connector (2) must engage audibly.

### ► Connecting all battery earth leads

- See additional information.



### ► Activating the 48 V electrical system

#### Prerequisite

Ignition is switched off.



#### Damage to 48-V battery

**If a 48-V battery that is disconnected from the electrical system is activated, the battery electronics will be damaged.**

- Only carry out activation of the 48V electrical system with a completely connected 48-V battery.



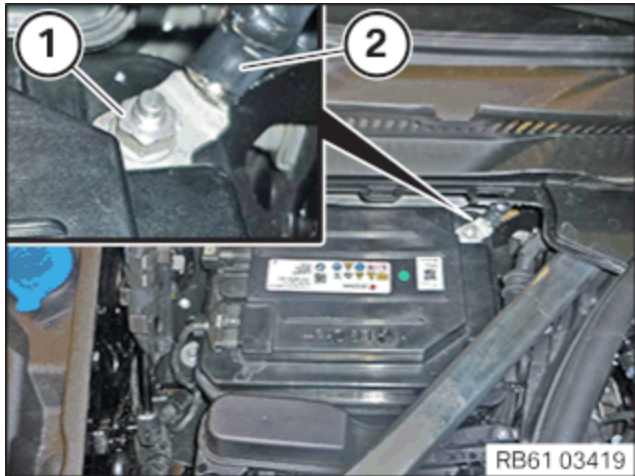

- Release the negative battery cable (2) of the 48-V battery from the mounting.
- Position the negative battery cable (2) of the 48-V battery on the negative battery terminal.
- Tighten nut (1).

#### **Negative battery cable to 48-V battery**

Nut M8

Tightening  
torque

19 Nm

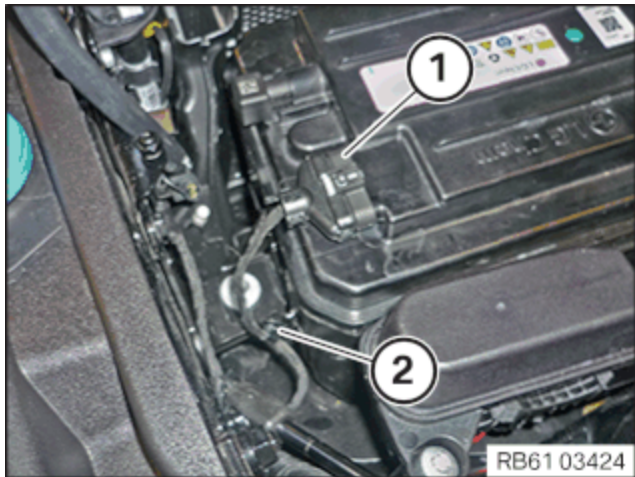

- Connect the connector (1) of the CAN bus and lock it.
- Clip in clip (2).





### 34 – Installing the rear seat bench

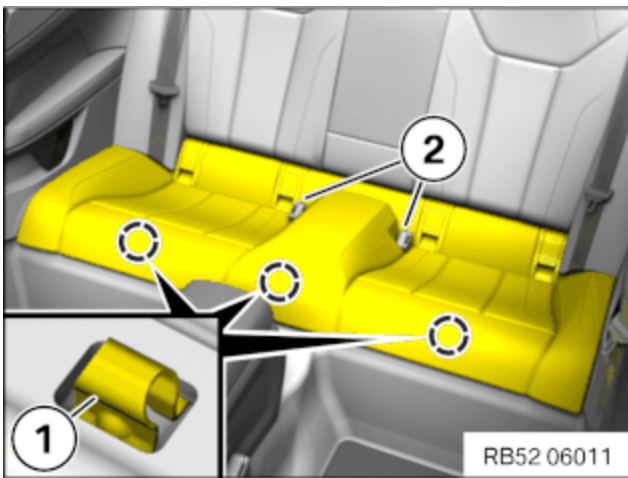

- Feed in the seat belt buckles (2).
- Position the rear seat bench and clip into the clamps (1).

## Additional Information

### Overview of Tightening Torques

Headlining to C-pillar		Used in step	18
Oval-head screw	Tightening torque		1.6 Nm
Roof function centre (FZD)		Used in step	20
	Tightening torque		1.2 Nm
A-pillar trim panel to body		Used in step	25
Sheet metal screw 4,8x38	Tightening torque		2,6 Nm
C-pillar trim panel to body		Used in step	27
Sheet metal screw	Tightening torque		2 Nm



**Negative battery cable to 48-V battery**Used in step [33](#)

Nut M8

Tightening torque

19 Nm

**Overview of Special Tools**



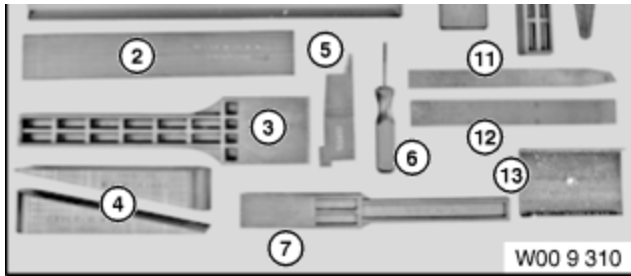

included in the tool or work 0 490 527

Storage location Individual

Replaced by

In connection with

SI-Number 01 07 09 (530)

### 0 496 569 (00 9 325) Wedge



**Common** Used in step [13](#)

---

Usage (Panel wedge) From 11/2008 this special tool replaces panel wedge 00 9 317 (different material)

Included in the tool or work 0 490 527

Storage location Individual

Replaced by

In connection with

SI-Number 41 01 09 (507)

### 0 493 687 (00 9 340) Removal aid

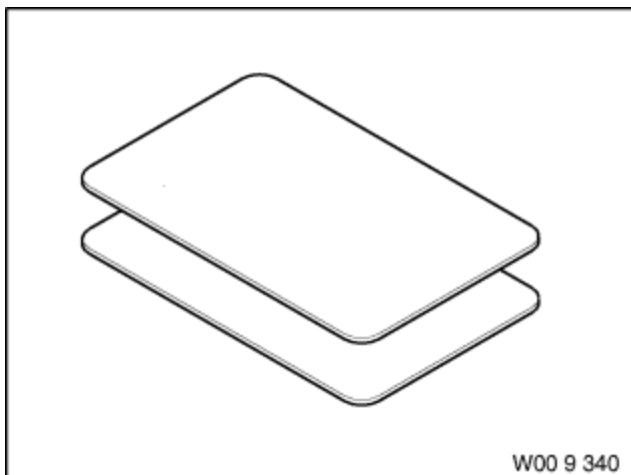

**Common** Used in step [14](#)

---

Usage (Dismantling aid (2 pieces))

Included in the tool or work

Storage location C2

Replaced by

In connection with

1 [0 496 289 \(00 9 341\)](#)

**Removal aid**  
Only available as a set (2 tools) under 00 9 340 (= 83 30 0 493 687).

**2 298 505 Wedge**

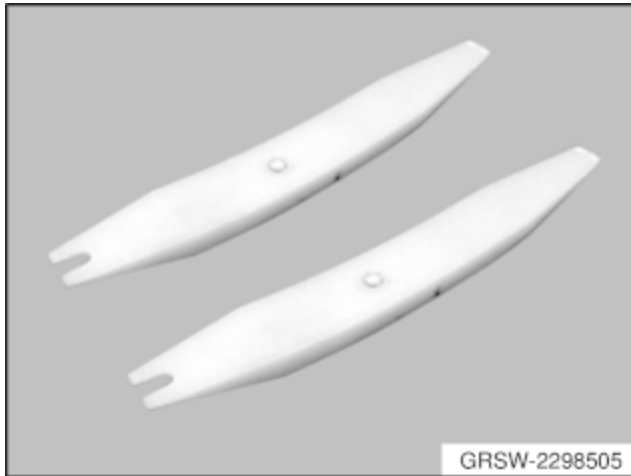

<b>Common</b>		Used in step	<b>20</b>
Usage	Set (delivery of 2 pieces)		
Included in the tool or work			
Storage location	C34		
Replaced by			
In connection with			
SI-Number	01 03 12 (792)		

**Links**

**Repair instructions (PRE)** **Used in step**

[Notes on 48-V battery](#) 2 33

**General repair instructions** **Used in step**

[72 00 ... Safety regulations for handling components with gas generators](#) 2 10 33

[72 00 ... Safety regulations for handling components with gas generators](#) 10

**Repair instructions** **Used in step**

[61 20 900 Disconnecting and connecting the battery earth lead \(all battery earth leads\)](#) 2 33

[61 20 900 Disconnecting and connecting battery earth lead](#) 2 33

[61 20 900 Disconnecting and connecting battery earth lead](#) 2 33

[61 20 900 Disconnecting and connecting battery earth lead](#) 2 33

[61 20 900 Disconnecting and connecting battery earth lead](#) 2 33



<a href="#">61 20 900 Disconnecting and connecting battery earth lead</a>	2	33
<a href="#">61 20 900 Disconnecting and connecting battery earth lead</a>	2	33
<a href="#">61 20 900 Disconnecting and connecting battery earth lead</a>	2	33

For informational purposes only. The information on this website is provided AS-IS with no warranties, express or implied, and is not guaranteed to be error-free, up-to-date or complete. NewTIS and BMW assume no liability for any loss or damage arising from the use or reliance on the information and content on this website. The content on this website is subject to change without notice.

